

Type D3 PROTECTOSPRAY Directional Spray Nozzles, Open, Medium Velocity

General Description

The TYCO Type D3 PROTECTOSPRAY Nozzles are open (non-automatic) directional spray nozzles and they are designed for use in water spray fixed systems for fire protection applications. They are external deflector type nozzles that discharge a uniformly filled cone of medium velocity water droplets.

The D3 Nozzles are effective in covering exposed vertical, horizontal, curved, and irregular shaped surfaces in a cooling spray to prevent excessive absorption of heat from an external fire and possible structural damage or spread of fire to the protected equipment. In some applications, depending on water design density requirements, the Type D3 Nozzles may also be used for fire control or extinguishment.

The Type D3 Nozzles are available in a wide variety of orifice sizes and spray angles (included angle of discharge) to provide versatility in system design. Refer to Technical Data Sheet TFP890 for information on Blow-Off Plugs that can be used for applications where protection is required against insect infestation or accumulation of debris within the nozzle orifice.

It is recommended that the end user be consulted with respect to the suitability of the materials of construction and finish for any given corrosive environment. The effects of ambient tempera-

ture, concentration of chemicals, and gas/chemical velocity, should be considered, at a minimum, along with the corrosive nature to which the sprinklers may be exposed.

The Type D3 PROTECTOSPRAY Nozzle is a re-designation for the Gem Type D3.

NOTICE

The Type D3 PROTECTOSPRAY Nozzles described herein must be installed and maintained in compliance with this document, and with the applicable standards of the NATIONAL FIRE PROTECTION ASSOCIATION, in addition to the standards of any authorities having jurisdiction. Failure to do so may impair the performance of these devices.

The design of individual water spray fixed systems can vary considerably, depending on the characteristics and nature of the hazard, the basic purpose of the spraying system, the configuration of the hazard, and wind/draft conditions. Because of these variations as well as the wide range of available nozzle spray characteristics, the design of water spray fixed systems for fire protection must only be performed by experienced designers who thoroughly understand the limitations as well as capabilities of such systems.

The owner is responsible for maintaining their fire protection system and devices in proper operating condition. Contact the installing contractor or product manufacturer with any questions.



Technical Data

Approvals

The natural finish, chrome plated, and lead coated bronze, as well as stainless steel Type D3 PROTECTOSPRAY Nozzles are UL and C-UL Listed, as well as FM Approved.

Maximum Working Pressure

175 psi (12,1 bar)

Also refer to Figure 2, Note 2

Discharge Coefficient

Refer to Table A

Spray Angles

Refer to Table B

Finish and Material

Refer to Table E

Thread Connection

1/2 inch NPT

Physical Characteristics (Bronze)

Frame	Bronze
Deflector	Bronze
Splitter	Bronze
Pin	Bronze

Physical Characteristics (Stainless Steel)

Frame	ASTM A-743 Grade CF-8M (equiv. Type 316 S.S.)
Deflector	Type 316 S.S.
Splitter	Type 316 S.S.
Pin	Type 316 S.S.

IMPORTANT

Refer to Technical Data Sheet TFP2300 for warnings pertaining to regulatory and health information.

Always refer to Technical Data Sheet TFP700 for the "INSTALLER WARNING" that provides cautions with respect to handling and installation of sprinkler systems and components. Improper handling and installation can permanently damage a sprinkler system or its components and cause the sprinkler to fail to operate in a fire situation or cause it to operate prematurely.

Design Criteria

Nozzle Placement. Where direct impingement of water spray onto all of the protected surface is required by the authority having jurisdiction, the nozzles are to be spaced and directed so that their spray patterns will completely cover the plane-of-protection with the minimum required average density; however, it is recommended that indoor nozzle spacing be 12 ft. (3,7 m) or less and that outdoor nozzle spacing be 10 ft. (3,0 m) or less. Where rundown or slippage is planned, such as, exposure protection of vessels per NFPA 15, the above recommended indoor and outdoor spacings also apply.

When used for protecting the surfaces of a vessel, for example, the nozzles are positioned normal to and approximately 2 ft. (0,6 m) from the surface. This approach, in conjunction with a properly selected spray angle, will tend to make more effective use of the spray as well as help minimize the disturbance effects of wind/draft conditions on the water spray patterns.

Spray Patterns. The Design Spray Profiles for the nozzle spray angles of 65 to 180 degrees are shown in Figure 2 and apply to discharge pressures of 20 to 60 psi (1,4 to 4,1 bar). Discharge pressures in excess of 60 psi (4,1 bar) will result in a decrease in coverage area since the spray patterns tend to draw inwards at higher pressures. Refer inquiries on higher discharge pressures to the Technical Services Department. The maximum axial distances between the nozzle tip and plane-of-protection, for exposure protection, are given in Table C and D. When the axial distance from the nozzle tip to the plane-of-protection is 2 ft. (0,6 m) or less, the Design Spray Profile is the same as the nominal spray angles of 65 thru 140 degrees.

Main Pipeline Strainers. Main pipeline strainers per NFPA 15 are required for systems utilizing nozzles with a flow path less than 3/8 in. (9,5 mm) diameter, i.e., No. 16 thru No. 24 (Ref. Table A), and for any system where the water is likely to contain obstructive material.

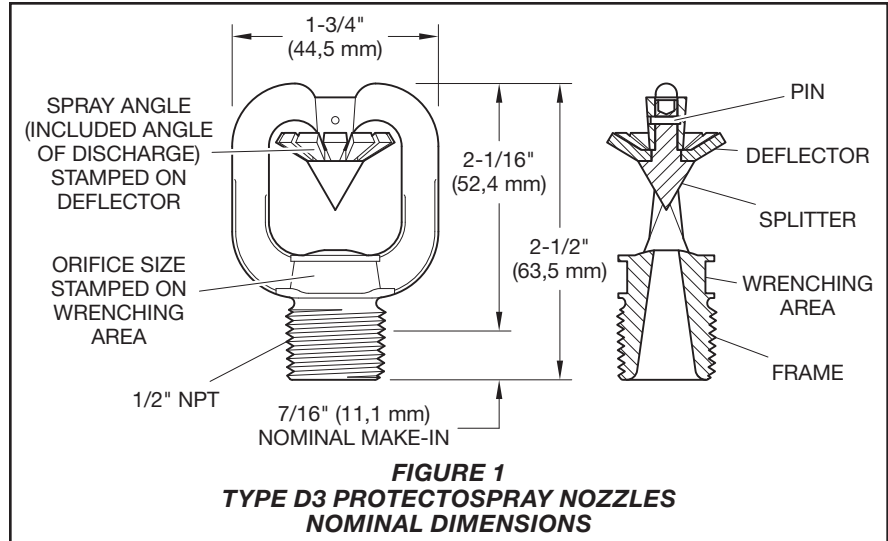

ORIFICE SIZE	MINIMUM DIAMETER	K-FACTOR	
		GPM/psi ^{1/2}	LPM/bar ^{1/2}
NO. 16	0.203" (5,16 mm)	1.2	17,3
NO. 18	0.250" (6,35 mm)	1.8	25,9
NO. 21	0.281" (7,14 mm)	2.3	33,1
NO. 24	0.328" (8,33 mm)	3.0	43,2
NO. 28	0.375" (9,53 mm)	4.1	59,0
NO. 32	0.438" (11,13 mm)	5.6	80,6
NO. 34	0.500" (12,70 mm)	7.2	103,7

TABLE A
SELECTION OF ORIFICE SIZES

65°	80°	95°	110°	125°	140°	160°	180°
-----	-----	-----	------	------	------	------	------

TABLE B
SELECTION OF SPRAY ANGLES

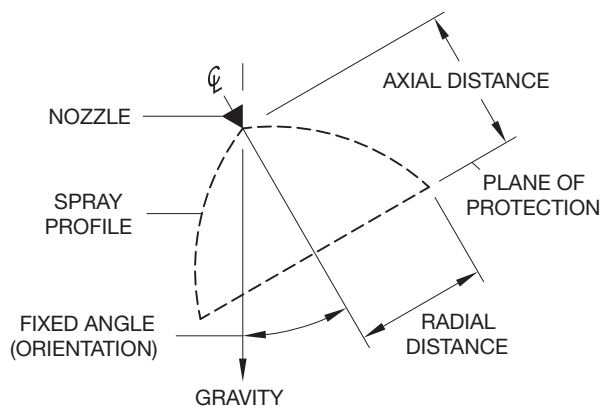
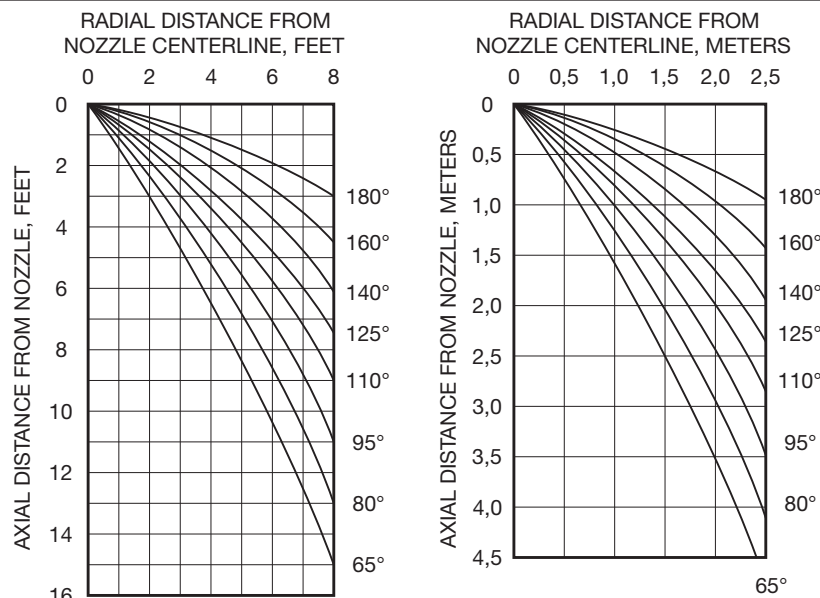

NOTES:

1. Design data obtained from tests in still air.
2. Design data applies to a residual (flowing) pressure range at the nozzle inlet of 20 to 60 psi (1,4 to 4,1 bar). For pressures up to 175 psi (12,1 bar) consult Johnson Controls Technical Services.
Refer to the authority having jurisdiction for their minimum required residual pressures.
3. The shapes of the Design Spray Profiles remain essentially unchanged over the maximum Axial Distances shown in Tables C and D.
4. For axial distances of 2 feet (0,6 meters) and less and for nozzle spray angles of 65° to 140°, the Design Spray Profile is the same as the nominal spray angle.
5. The maximum Axial Distances shown in Tables C and D are based on exposure protection.

FIGURE 2
WATER DISTRIBUTION DESIGN DATA

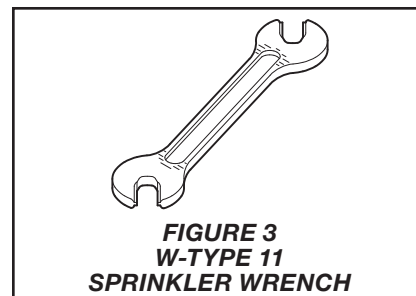

FIGURE 3
W-TYPE 11
SPRINKLER WRENCH

Installation

The TYCO Type D3 Protectospray Nozzles must be installed in accordance with this section.

General Instructions

A leak-tight 1/2 inch NPT nozzle joint should be obtained by applying a minimum to maximum torque of 7 to 14 ft.-lbs. (9,5 to 19,0 Nm). Higher levels of torque may cause impairment of the nozzle.

Step 1. With pipe-thread sealant applied to the pipe threads, hand tighten the nozzle into the nozzle fitting.

Step 2. Tighten the nozzle into the nozzle fitting using only the W-Type 11 Sprinkler Wrench (Figure 3). With reference to Figure 1, apply the W-Type 11 Sprinkler Wrench to the wrenching area.

MAXIMUM AXIAL DISTANCE FOR 65° SPRAY ANGLE IN FEET AND INCHES							
FIXED ANGLE	ORIFICE SIZE						
	16	18	21	24	28	32	34
0°	10-6	12-6	13-0	13-3	14-6	15-0	15-6
30°	8-3	10-9	10-9	11-9	12-6	13-6	13-9
45°	7-3	10-0	10-0	11-3	11-6	12-6	12-9
60°	6-6	9-3	9-6	10-9	11-0	11-9	12-6
90°	6-0	8-6	9-0	10-3	10-6	10-9	11-6
120°	5-9	7-6	7-6	7-6	8-3	9-0	9-6
135°	5-3	6-0	6-3	6-6	7-0	8-0	8-6
150°	5-3	5-6	5-6	5-9	6-3	7-3	7-6
180°	5-0	5-0	5-0	5-6	5-9	6-6	7-0

MAXIMUM AXIAL DISTANCE FOR 125° SPRAY ANGLE IN FEET AND INCHES							
FIXED ANGLE	ORIFICE SIZE						
	16	18	21	24	28	32	34
0°	4-6	5-0	6-6	7-9	10-0	10-3	10-6
30°	3-9	3-9	6-3	6-9	8-6	8-6	8-9
45°	3-0	3-6	5-9	6-0	7-9	7-6	8-3
60°	2-6	3-0	5-6	5-9	7-3	7-3	7-9
90°	2-0	2-9	4-9	5-0	5-9	6-0	6-6
120°	1-9	2-3	3-3	3-3	3-9	3-9	4-6
135°	1-6	1-9	2-6	2-6	3-3	3-3	3-9
150°	1-6	1-6	2-0	2-3	2-6	2-9	3-6
180°	1-3	1-3	1-9	2-0	2-3	2-6	3-3

MAXIMUM AXIAL DISTANCE FOR 80° SPRAY ANGLE IN FEET AND INCHES							
FIXED ANGLE	ORIFICE SIZE						
	16	18	21	24	28	32	34
0°	9-0	10-6	11-0	12-0	13-0	14-0	14-0
30°	7-3	8-3	8-9	10-6	11-6	12-3	12-3
45°	6-3	7-6	8-0	10-3	10-6	11-3	11-3
60°	5-6	7-0	7-6	10-0	10-3	10-9	10-9
90°	5-0	6-0	7-0	9-3	9-6	9-9	10-0
120°	4-6	4-9	5-9	6-6	7-3	7-0	8-0
135°	4-3	4-6	5-0	5-6	6-0	6-3	6-9
150°	4-0	4-0	4-6	5-0	5-6	5-6	6-0
180°	3-9	3-9	4-0	4-6	4-9	5-3	5-6

MAXIMUM AXIAL DISTANCE FOR 140° SPRAY ANGLE IN FEET AND INCHES							
FIXED ANGLE	ORIFICE SIZE						
	16	18	21	24	28	32	34
0°	4-0	4-6	6-0	6-6	8-0	8-0	8-0
30°	3-3	3-6	5-6	5-6	6-3	7-0	7-0
45°	2-9	2-9	5-0	5-0	5-6	6-6	6-6
60°	2-3	2-6	4-6	4-6	5-3	5-6	5-9
90°	1-9	2-3	4-0	4-0	4-6	4-6	5-0
120°	1-6	1-9	2-3	2-3	2-6	3-0	3-6
135°	1-3	1-6	1-6	1-6	2-0	2-6	2-9
150°	1-3	1-3	1-6	1-6	1-9	2-3	2-6
180°	1-0	1-0	1-3	1-3	1-6	2-0	2-3

MAXIMUM AXIAL DISTANCE FOR 95° SPRAY ANGLE IN FEET AND INCHES							
FIXED ANGLE	ORIFICE SIZE						
	16	18	21	24	28	32	34
0°	7-0	7-9	9-6	10-6	11-0	12-0	12-6
30°	5-9	6-6	7-9	9-9	10-6	10-9	11-0
45°	5-3	6-3	7-0	9-6	9-9	10-3	10-3
60°	4-9	6-0	6-9	9-3	9-6	9-9	9-9
90°	4-0	5-0	6-6	8-3	8-6	8-9	8-9
120°	3-6	3-9	5-0	5-3	6-3	6-0	6-6
135°	3-3	3-6	4-0	4-6	5-3	5-3	5-6
150°	3-0	3-0	3-6	4-0	4-6	4-6	4-9
180°	3-0	3-0	3-3	3-9	4-0	4-3	4-6

MAXIMUM AXIAL DISTANCE FOR 160° SPRAY ANGLE IN FEET AND INCHES							
FIXED ANGLE	ORIFICE SIZE						
	16	18	21	24	28	32	34
0°	3-6	3-9	4-9	5-0	6-0	6-9	7-0
30°	2-9	3-0	4-3	4-6	5-0	5-9	6-3
45°	2-3	2-6	3-9	4-0	4-6	5-3	5-6
60°	1-9	2-3	3-6	3-9	4-3	4-9	5-3
90°	1-3	1-9	3-0	3-3	3-6	3-9	4-3
120°	1-0	1-3	1-6	2-0	2-0	2-3	2-6
135°	1-0	1-0	1-3	1-3	1-6	1-9	2-0
150°	0-9	0-9	1-0	1-0	1-6	1-6	1-9
180°	0-9	0-9	0-9	0-9	1-3	1-6	1-6

MAXIMUM AXIAL DISTANCE FOR 110° SPRAY ANGLE IN FEET AND INCHES							
FIXED ANGLE	ORIFICE SIZE						
	16	18	21	24	28	32	34
0°	6-0	7-0	9-0	9-6	11-0	11-3	11-6
30°	5-3	6-3	7-3	8-9	9-6	9-9	10-0
45°	4-9	5-9	6-6	8-6	9-0	9-0	9-3
60°	4-3	5-6	6-3	8-3	8-6	8-6	8-9
90°	3-6	4-6	5-9	7-6	7-6	7-6	7-9
120°	2-9	3-3	4-6	4-6	5-6	5-6	5-6
135°	2-6	2-9	3-6	3-6	4-6	4-6	4-9
150°	2-3	2-6	3-0	3-3	3-6	3-9	4-3
180°	2-3	2-3	2-9	3-0	3-3	3-6	3-9

MAXIMUM AXIAL DISTANCE FOR 180° SPRAY ANGLE IN FEET AND INCHES							
FIXED ANGLE	ORIFICE SIZE						
	16	18	21	24	28	32	34
0°	2-9	3-0	3-6	3-6	4-0	6-0	6-0
30°	2-3	2-3	3-6	3-6	3-9	5-0	5-0
45°	1-9	2-0	3-3	3-3	3-6	4-3	4-3
60°	1-6	1-9	2-9	2-9	3-3	3-9	3-9
90°	1-0	1-6	2-0	2-0	2-6	3-0	3-0
120°	0-9	1-0	1-0	1-0	1-6	1-6	1-6
135°	0-6	0-9	0-9	0-9	1-3	1-3	1-3
150°	0-6	0-6	0-6	0-6	1-0	1-0	1-0
180°	0-6	0-6	0-6	0-6	0-9	0-9	0-9

TABLE C
MAXIMUM AXIAL DISTANCE BETWEEN NOZZLE TIP AND
PLANE-OF-PROTECTION FOR EXPOSURE PROTECTION – FEET AND INCHES

MAXIMUM AXIAL DISTANCE FOR 65° SPRAY ANGLE IN METERS							
FIXED ANGLE	ORIFICE SIZE						
	16	18	21	24	28	32	34
0°	3,2	3,8	4,0	4,0	4,4	4,6	4,7
30°	2,5	3,3	3,3	3,6	3,8	4,1	4,2
45°	2,2	3,0	3,0	3,4	3,5	3,8	3,9
60°	2,0	2,8	2,9	3,3	3,4	3,6	3,8
90°	1,8	2,6	2,7	3,1	3,2	3,3	3,5
120°	1,8	2,3	2,3	2,3	2,5	2,7	2,9
135°	1,7	1,8	1,9	2,0	2,1	2,4	2,6
150°	1,6	1,7	1,7	1,9	1,9	2,2	2,3
180°	1,5	1,5	1,5	1,7	1,8	2,0	2,1

MAXIMUM AXIAL DISTANCE FOR 125° SPRAY ANGLE IN METERS							
FIXED ANGLE	ORIFICE SIZE						
	16	18	21	24	28	32	34
0°	1,4	1,5	2,0	2,4	3,0	3,1	3,2
30°	1,1	1,1	1,9	2,1	2,6	2,6	2,7
45°	0,9	1,1	1,8	1,8	2,4	2,3	2,5
60°	0,8	0,9	1,7	1,8	2,2	2,2	2,4
90°	0,6	0,8	1,4	1,5	1,8	1,8	2,0
120°	0,5	0,7	1,0	1,0	1,1	1,1	1,4
135°	0,5	0,5	0,8	0,8	1,0	1,0	1,1
150°	0,5	0,5	0,6	0,7	0,8	0,8	1,1
180°	0,4	0,4	0,5	0,6	0,7	0,8	1,0

MAXIMUM AXIAL DISTANCE FOR 80° SPRAY ANGLE IN METERS							
FIXED ANGLE	ORIFICE SIZE						
	16	18	21	24	28	32	34
0°	2,7	3,2	3,4	3,7	4,0	4,3	4,3
30°	2,2	2,5	2,7	3,2	3,5	3,7	3,7
45°	1,9	2,3	2,4	3,1	3,2	3,4	3,4
60°	1,7	2,1	2,3	3,0	3,1	3,3	3,3
90°	1,5	1,8	2,1	2,8	2,9	3,0	3,0
120°	1,4	1,4	1,8	2,0	2,2	2,1	2,4
135°	1,3	1,4	1,5	1,7	1,8	1,9	2,1
150°	1,2	1,2	1,4	1,5	1,7	1,7	1,8
180°	1,1	1,1	1,2	1,4	1,4	1,6	1,7

MAXIMUM AXIAL DISTANCE FOR 140° SPRAY ANGLE IN METERS							
FIXED ANGLE	ORIFICE SIZE						
	16	18	21	24	28	32	34
0°	1,2	1,4	1,8	2,0	2,4	2,4	2,4
30°	1,0	1,1	1,7	1,7	1,9	2,1	2,1
45°	0,8	0,8	1,5	1,5	1,7	2,0	2,0
60°	0,7	0,8	1,4	1,4	1,6	1,7	1,8
90°	0,5	0,7	1,2	1,2	1,4	1,4	1,5
120°	0,5	0,5	0,7	0,8	0,8	0,9	1,1
135°	0,4	0,5	0,5	0,5	0,6	0,8	0,8
150°	0,4	0,4	0,5	0,5	0,5	0,7	0,8
180°	0,3	0,3	0,4	0,4	0,5	0,6	0,7

MAXIMUM AXIAL DISTANCE FOR 95° SPRAY ANGLE IN METERS							
FIXED ANGLE	ORIFICE SIZE						
	16	18	21	24	28	32	34
0°	2,1	2,4	2,9	3,2	3,4	3,7	3,8
30°	1,8	2,0	2,4	3,0	3,2	3,3	3,4
45°	1,6	1,9	2,1	2,9	3,0	3,1	3,1
60°	1,4	1,8	2,1	2,8	2,9	3,0	3,0
90°	1,2	1,5	2,0	2,5	2,6	2,7	2,7
120°	1,1	1,1	1,5	1,6	1,9	1,8	2,0
135°	1,0	1,1	1,2	1,4	1,6	1,6	1,7
150°	0,9	0,9	1,1	1,2	1,4	1,4	1,4
180°	0,9	0,9	1,1	1,1	1,2	1,3	1,4

MAXIMUM AXIAL DISTANCE FOR 160° SPRAY ANGLE IN METERS							
FIXED ANGLE	ORIFICE SIZE						
	16	18	21	24	28	32	34
0°	1,1	1,1	1,4	1,5	1,8	2,1	2,1
30°	0,8	0,9	1,3	1,4	1,5	1,8	1,9
45°	0,7	0,8	1,1	1,2	1,4	1,6	1,7
60°	0,5	0,7	1,1	1,1	1,1	1,4	1,6
90°	0,4	0,5	0,9	1,0	0,7	1,1	1,3
120°	0,3	0,4	0,5	0,6	0,5	0,7	0,8
135°	0,3	0,3	0,4	0,4	0,5	0,5	0,6
150°	0,2	0,2	0,3	0,3	0,5	0,5	0,5
180°	0,2	0,2	0,2	0,2	0,5	0,5	0,5

MAXIMUM AXIAL DISTANCE FOR 110° SPRAY ANGLE IN METERS							
FIXED ANGLE	ORIFICE SIZE						
	16	18	21	24	28	32	34
0°	1,8	2,1	2,7	2,9	3,4	3,4	3,5
30°	1,6	1,9	2,2	2,7	2,9	3,0	3,0
45°	1,4	1,8	2,0	2,6	2,7	2,7	2,8
60°	1,3	1,7	1,9	2,5	2,6	2,6	2,7
90°	1,1	1,4	1,8	2,3	2,3	2,3	2,4
120°	0,8	1,0	1,4	1,4	1,7	1,7	1,7
135°	0,8	0,8	1,1	1,1	1,4	1,4	1,4
150°	0,7	0,8	0,9	1,0	1,1	1,1	1,3
180°	0,7	0,7	0,8	0,9	1,1	1,1	1,1

MAXIMUM AXIAL DISTANCE FOR 180° SPRAY ANGLE IN METERS							
FIXED ANGLE	ORIFICE SIZE						
	16	18	21	24	28	32	34
0°	0,8	0,9	1,1	1,1	1,2	1,8	1,8
30°	0,7	0,7	1,1	1,1	1,1	1,5	1,5
45°	0,5	0,6	1,0	1,0	1,1	1,3	1,3
60°	0,5	0,5	0,8	0,8	1,0	1,1	1,1
90°	0,3	0,5	0,6	0,6	0,8	0,9	0,9
120°	0,2	0,3	0,3	0,3	0,5	0,5	0,5
135°	0,2	0,2	0,2	0,2	0,4	0,4	0,4
150°	0,2	0,2	0,2	0,2	0,3	0,3	0,3
180°	0,2	0,2	0,2	0,2	0,2	0,2	0,2

TABLE D
MAXIMUM AXIAL DISTANCE BETWEEN NOZZLE TIP AND
PLANE-OF-PROTECTION FOR EXPOSURE PROTECTION – METERS

P/N* 49 — 3XX — X — XXX

ORIFICE SIZE	
16	NO. 16
18	NO. 18
21	NO. 21
24	NO. 24
28	NO. 28
32	NO. 32
34	NO. 34

FINISH & MATERIAL	
1	NATURAL FINISH BRONZE
4	TEFLON COATED BRONZE
7	LEAD COATED BRONZE
9	CHROME PLATED BRONZE
0	NATURAL FINISH STAINLESS STEEL

SPRAY ANGLE	
065	65°
080	80°
095	95°
110	110°
125	125°
140	140°
160	160°
180	180°

* Use Suffix "I" for the ISO 7-1 connection; for example, 49-321-1-110-I

TABLE E
TYPE D3 PROTECTOSPRAY NOZZLES
PART NUMBER SELECTION

Care and Maintenance

The TYCO Type D3 PROTECTOSPRAY Nozzles must be maintained and serviced in accordance with this section.

Before closing a fire protection system main control valve for maintenance work on the fire protection system that it controls, permission to shut down the affected fire protection system must be obtained from the proper authorities and all personnel who may be affected by this action must be notified.

Type D3 PROTECTOSPRAY Nozzles must never be painted, plated, coated or altered in any way after leaving the factory; otherwise, the spray performance may be impaired.

Care must be exercised to avoid damage to the nozzles before, during, and after installation. Nozzles damaged by dropping, striking, wrench twist/slip-page, or the like, must be replaced.

Frequent visual inspections are recommended to be initially performed for nozzles installed in potentially corrosive atmospheres to verify the integrity of the materials of construction and finish as they may be affected by the corrosive conditions present for a given installation. Thereafter, annual inspections per NFPA 25 are required.

Water spray fixed systems for fire protection service require regularly scheduled care and maintenance by trained

personnel. In addition to inspecting nozzles for proper spray performance during water flow trip tests of the system, it is recommended that nozzles be periodically inspected for broken or missing parts (including blow-off plugs where applicable), loading/obstructions, or other evidence of impaired protection. The inspections should be scheduled weekly or as frequently as may be necessary, and corrective action must be taken to ensure that the nozzles will perform as intended in the event of a fire.

For installations subject to freezing and where blow-off plugs have been installed, a periodic inspection must be performed for evidence of ice build-up from trapped condensate which could affect the proper release of the blow-off plugs.

The owner is responsible for the inspection, testing, and maintenance of their fire protection system and devices in compliance with this document, as well as with the applicable standards of the NATIONAL FIRE PROTECTION ASSOCIATION (e.g., NFPA 25), in addition to the standards of any other authorities having jurisdiction. Contact the installing contractor or product manufacturer with any questions.

Water spray fixed systems are recommended to be inspected, tested, and maintained by a qualified Inspection Service in accordance with local requirements and/or national codes.

Limited Warranty

For warranty terms and conditions, visit www.tyco-fire.com.

Ordering Procedure

Contact your local distributor for availability. When placing an order, indicate the full product name and Part Number (P/N).

D3 PROTECTOSPRAY Nozzles

Specify: No. (orifice), Type D3 PROTECTOSPRAY Nozzle with (finish/coating and material) with (number) degree spray angle, P/N (from table E)

Sprinkler Wrench

Specify: W-Type 11 Sprinkler Wrench, P/N 56-452-1-001

Optional Blow-Off Plugs

Specify: Blow-Off Plug Style (letter), P/N (specify):

(No.16) Style A	56-320-1-001
(No.18) Style K	56-320-1-009
(No.21) Style J	56-320-1-008
(No.24) Style I	56-320-1-007
(No.28) Style H	56-320-1-006
(No.32) Style E	56-320-1-005
(No.34) Style D	56-320-1-004